

## *Warranty Certificate*

*This instrument is warranted against any manufacturing defects for a period of twelve months from the date of installation, or eighteen months from the date of supply, which ever is early.*

**Kindly note that:**

1. *The warranty is limited to repairing the instrument and no responsibility is taken for any other damage resulted*
2. *The warranty will be void if the instrument is opened or tampered in any way*
3. *The faulty instrument has to be returned to our factory, carriage prepaid & duly insured.*

Product Category	: Flow Indicator Totalizer
Model No.	: FIT 9223 / 9225
Serial number	: _____
Date of despatch	: _____
Authorized signatory	: _____
Company seal	

## *FLOW INDICATOR TOTALIZER FIT 9223 / 9225*

### The Inside Stuff

<b>As You Unpack</b>	..... 2
<b>Introduction</b>	..... 3
<b>Principle Of Operation</b>	..... 4
<b>Features</b>	..... 4
<b>Specifications</b>	..... 5
<b>Illustrations</b>	..... 6
<b>Operation</b>	..... 9
<b>Installation Procedure</b>	..... 10
<b>Programming Flow Chart</b>	..... 11
<b>Programming Procedure</b>	..... 12
<b>Entering Program Mode Password</b>	..... 15
<b>Detailed Programming Flow chart</b>	..... 16
<b>Modbus poll illustration</b>	..... 20
<b>Input and Output Calibration Procedure</b>	..... 22
<b>Warranty Certificate</b>	..... 24
<b>Test certificate</b>	..... enclosed



**Kindly forward this product manual to the end user. The user is requested to read the manual thoroughly before operating the instrument.**

## As you unpack

*Congratulations  
on buying a  
Flow Indicator Totalizer !*

As you unpack kindly ensure that

1. The material received is in good condition
2. You have received the following material:
  - a) Flow Indicator Totalizer as per your order
  - b) Mounting bracket pair
  - d) This manual along with Warranty certificate

In case of any discrepancies contact our customer support department immediately.

*We are sure you will get long and trouble free service  
from our system.*



### We need your feedback :

Every attempt is made to make this manual clear and easy to understand, so that the user can install, take care of and feel confident in using our product. We welcome your valued suggestions to help us improve this product as well as the document and make it more user friendly.

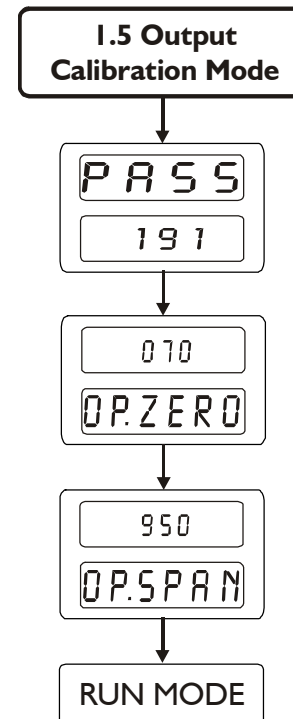

As user enters into output calibration mode password window will displayed as shown.



Calibration mode is password protected. The password is 191.



Connect a stable multimeter to the output terminals. By incr/shift keys adjust the count so that 4 mA is achieved at output.



By incr/ shift keys adjust the count so that 20 mA is achieved at output.



## Calibration procedure for Input and Output mode

**Warning :** This procedure is to be carried out strictly by  technically qualified personnel only.

The instrument is calibrated at the factory using 0.05 % accurate calibrating instruments. No calibration should be required in normal case, however if the instrument requires re-calibration, the procedure to be followed is given below.

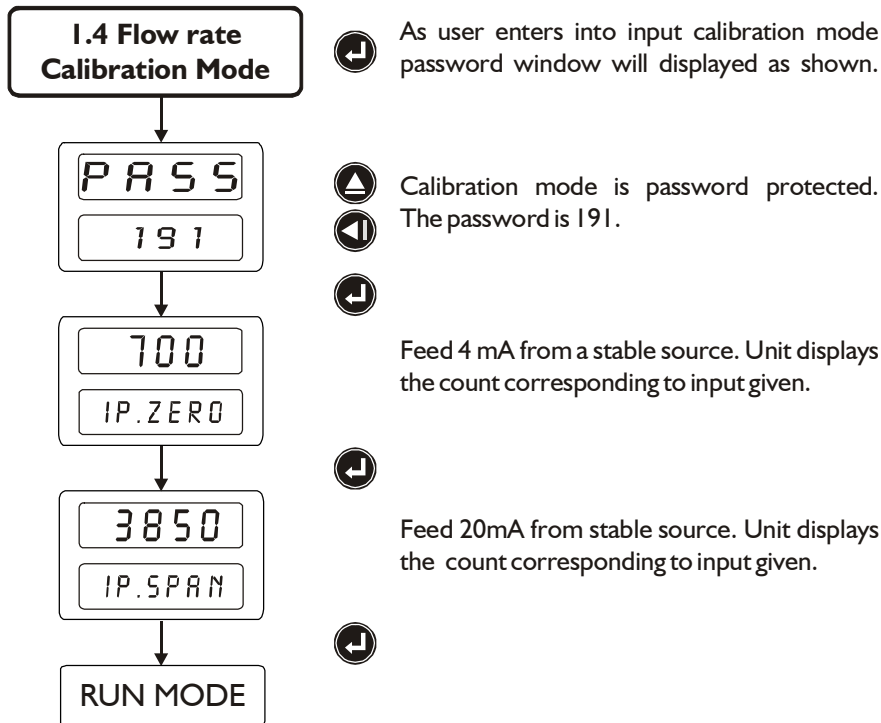

## Flow Indicator Totalizer

FIT 9223 / 9225

### Introduction



Flow indicators and totalizers play an important part in any process industry. Quick and accurate measurement and control of a process value will improve the final product quality, reliability and reduce rejection.

Process indication and control is therefore one of the prime considerations in any process industry

The FIT 92 series is a Microcontroller based Process Indicator cum Controller with user friendly programming facility. The FIT 92 has been designed for fast and accurate measurement and control of process value. Linearisation of signals provides high accuracy even for most nonlinear sensors. The instrument is designed using highly reliable electronic components. Process value is displayed directly in digits, giving better resolution.

The FIT 92 accepts 4 - 20 mA as input. Wide ranges of measurements are available depending on the sensor used.

The instrument is immune to mechanical vibrations. Even the mounting position will not affect the measurement accuracy.

Use of highly reliable electronic components with low temperature coefficient ensures long and trouble free service. The instrument is tested for its performance under various climatic conditions.

**Principle of Operation :**

The FIT 92 series is based on the principle high input impedance amplifier feeding an analog to digital convertor. The input signal generated by the transducer is fed to a signal conditioning amplifier, output of which is digitised by the ADC. This digital signal is linearised by software, displayed and compared to the set value by the microcontroller which initiates the programmed relay action. The linearisation, display and relays are controlled by the microcontroller by virtue of the system software.

**Features :**

- Microcontroller based logic
- Linear / Square root selection
- Highly accurate totalizing
- NVRAM enables data storage even in events of prolonged power failure
- Fast response time
- User selectable Control Logic
- Programming through tactile membrane keys
- RS 232 Modbus protocol supported
- Fail safe relay logic
- Maximum MTBF and minimum MTTR
- Highly compact
- Dust & vermin proof enclosure with epoxy powder coating.

**Function : Read Input Registers ( 04 )**

Message Format : (Request initiated by the master)

Slave Address	Function Code	Start Address ( Hi )	Start Address ( Lo )	No. of Points ( Hi )	No. of Points ( Lo )	Error Check ( Lo )	Error Check ( Hi )
---------------	---------------	----------------------	----------------------	----------------------	----------------------	--------------------	--------------------

Message Format : (Response by the slave for the request initiated by the master)

Slave Address	Function Code	Byte Count	Data ( Hi )	Data ( Lo )	Error Check ( Lo )	Error Check ( Hi )
---------------	---------------	------------	-------------	-------------	--------------------	--------------------

**Function : Preset Multiple Registers ( 16 )**

Message Format : (Request initiated by the master)

Slave Address	Function Code	Start Address ( Hi )	Start Address ( Lo )	No. of Registers ( Hi )	No. of Registers ( Lo )	Byte Count	Date Byte High	Date Byte Low	Error Check ( Lo )	Error Check ( Hi )
---------------	---------------	----------------------	----------------------	-------------------------	-------------------------	------------	----------------	---------------	--------------------	--------------------

Message Format : (Response by the slave for the request initiated by the master)

Slave Address	Function Code	Start Address ( Hi )	Start Address ( Lo )	No. of Registers ( Hi )	No. of Registers ( Lo )	Error Check ( Lo )	Error Check ( Hi )
---------------	---------------	----------------------	----------------------	-------------------------	-------------------------	--------------------	--------------------

Message Format : (Response by the slave for the invalid request initiated by the master)

Slave Address	Function Code	Exception Code	CRC Check Low	CRC Check High
---------------	---------------	----------------	---------------	----------------

## Modbus Protocol

Communication : RS 485  
 Protocol : MODBUS RTU  
 Device Address : Programmable from 1 to 247  
 Baud Rate : Selectable between 1200, 2400, 4800  
 9600 kbps

### Functions supported :

1. Read Input Registers ( 04 )
2. Preset Multiple Registers ( 16 )

### Exception Codes :

1. Invalid Function Code ( 01 )
2. Invalid Start Address ( 02 )
3. Invalid Data Value ( 03 )

### Starting address for flow and setpoints

Starting Address	Contents of the location
0000	Process Value
0001	Value of Setpoint No - 1
0002	Value of Setpoint No - 2

### Starting address for totalizer count

Starting Address	Contents of the location
0010	DIGIT 1 & 2
0011	DIGIT 3 & 4
0012	DIGIT 5 & 6

## Specifications

Model : FIT 9223 / 9225  
 Range of Flow rate : Programmable from 0 to 9999  
 Decimal point : Selectable  
 Input : 4 - 20 mA  
 Indication accuracy : +/- 0.1 % of FS +/- 1 digit  
 Accuracy deviation due to  
 a) Temperature change : ..... °C , ref at 25 °C  
 b) Supply Variation : +/- 0.01 % /V  
 Display for Flow : 4 digit, 12.5 mm seven segment RED LED  
 Display for Totalizer : 6 digit, 10 mm seven segment RED LED  
 Totalizer accuracy : Better than +/- 0.1 % , +/- 1 count  
 Totalizer reset : By 4 keys keypad  
 Setpointa : 2 nos. configurable on flow or totalizer  
 Setpoint Read & Adjust : Through Flat Membrane key pads and 4 digit display respectively on front panel  
 Outputs : 1 set of potential free Relay change over contacts rated 5 Amp resistive at 230 V AC per setpoint  
 Transmitter supply : 24 V DC, +/- 1V, @ 30 mA  
 Relay logic : User selectable High or Low.  
 Relay ON indication : 3 mm Red LED per setpoint  
 On / Off hysteresis : Programmable from 0.2 to 9.9 %  
 Interface : RS 485 (2 wire)  
 Protocol : Modbus RTU  
 Power supply : 230 V AC, +/- 10 % , 50 Hz  
 Ambient Temp. range : 5 to 55 °C  
 Power consumption : 6 VA  
 Mounting : Flush panel mounting  
 Dimensions and cutout : Refer table

Model	Facia	Cutout	Depth <sup>■</sup>
FIT 9223	96 x 96	92 x 92	80
FIT 9225	72 x 144	67 x 138	120

■ Depth Including Terminals

Programming protection : Password protected. Default password is 134.

Illustrations

A) Front view

FIT 9223

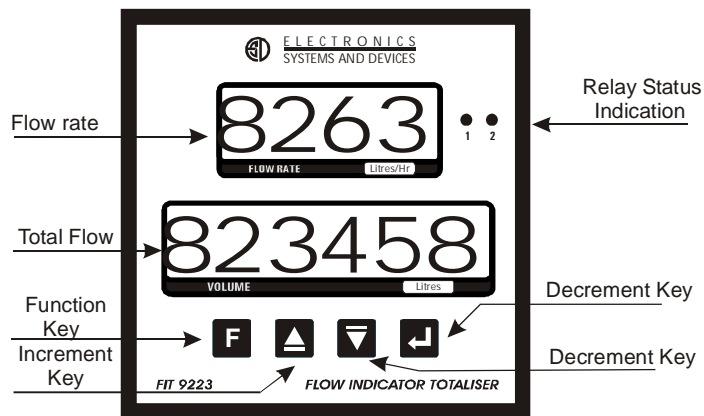

B) Rear view

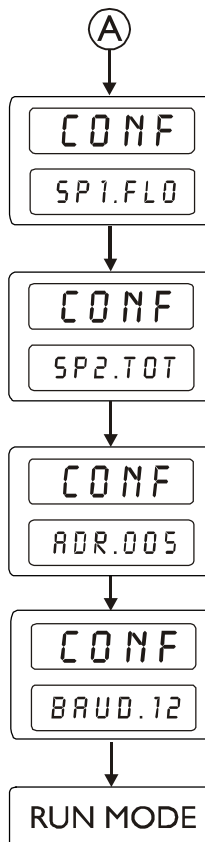
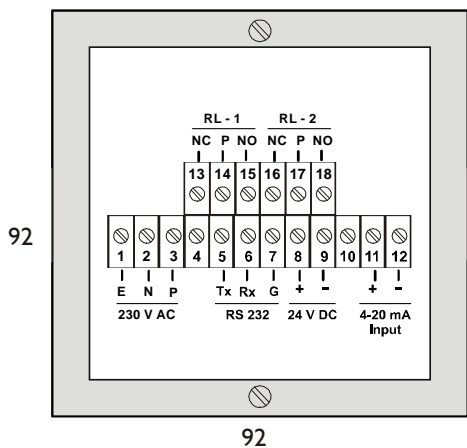

- ⬆️ Assign the setpoint no. 1 to flow or totalizer as per requirement
- ⬆️
- ⬆️ Assign the setpoint no. 2 to flow or totalizer as per requirement
- ⬆️
- ⬆️ Set device address between 1 to 247
- ⬆️
- ⬆️ Select baud rate between 1200, 2400, 4800 or 9600 kbps
- ⬆️

### I.3 Configuration Mode

CONF  
DP12.34



As user enters in the configuration mode display shows the message as below. At any point to change the value use increment and shift keys.

CONF  
LL000.0



Program the decimal position of flow rate as required.



CONF  
UL100.0



Program the lower limit of flow rate as required. This is the value which corresponds to 4 mA.



CONF  
OF001.1



Program the upper limit of flow rate as required. This is the value which corresponds to 20 mA.



CONF  
FT.LINR



Program the offset value of flow rate as required.



CONF  
TIME.MN



The input type can be selected between linear and square root type.



The time base can be selected between seconds, minutes and hour.

A



### Illustrations

A) Front view

FIT 9225

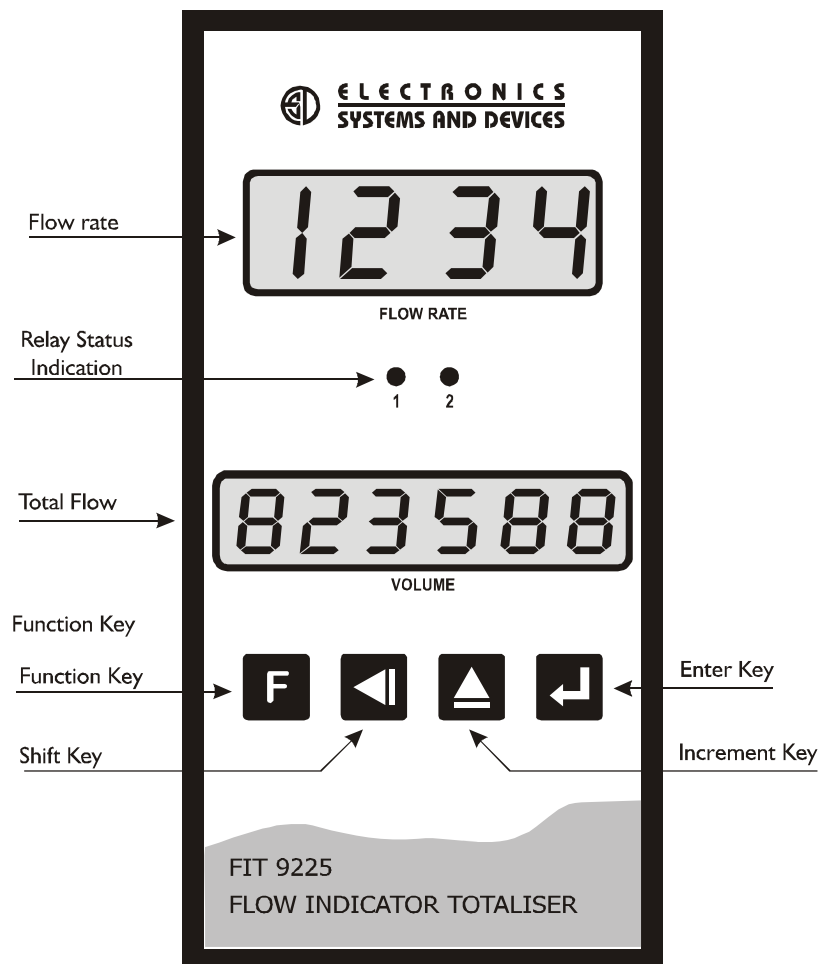

Rear view with communication

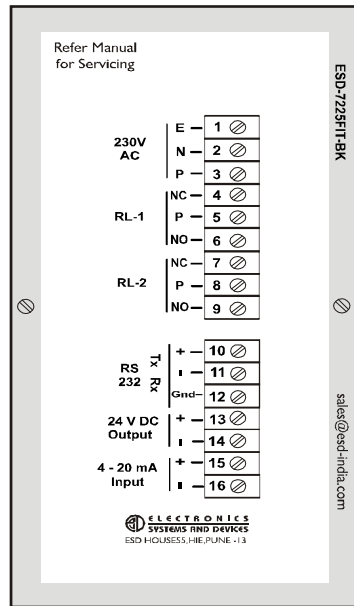

Rear view with Retransmission

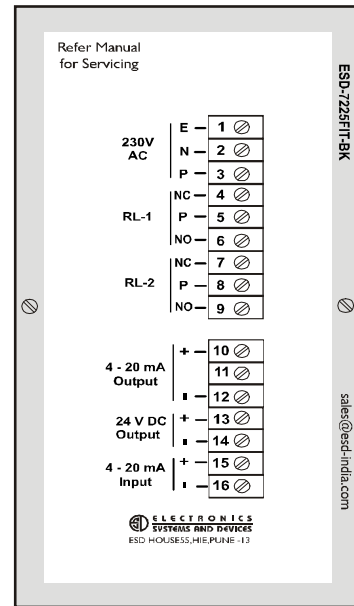

Input mA connection details:

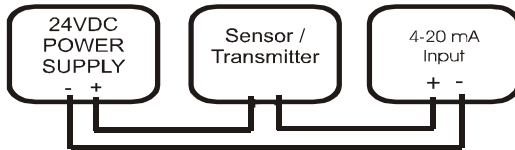

PC communication connection details:

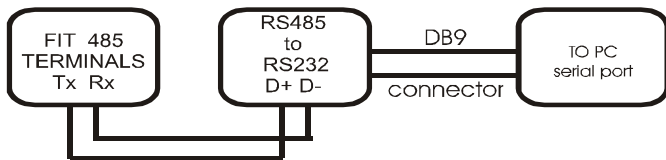

I.2 Setpoint Mode

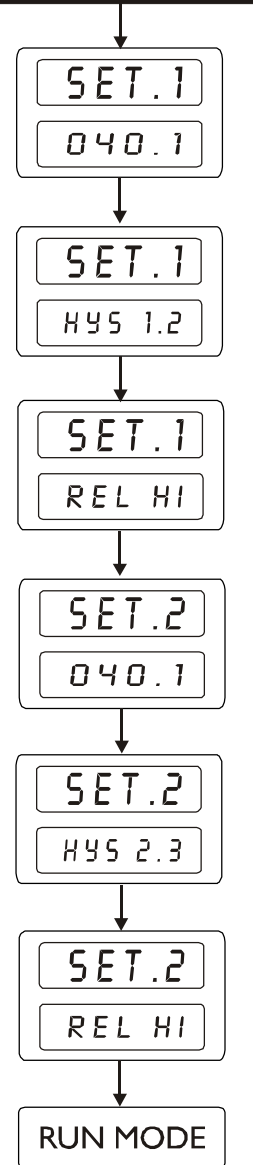

- As user enters in the setpoint mode display shows the message as below At any point to change the value use increment and shift keys.
- Indicates setpoint no. 1 is being programmed. All values followed by Enter key will be stored, else the value will be discarded.
- Program the hysteresis of setpoint no. 1 between 2 to 99 counts
- Program the relay logic of setpoint no. 1 between HI or LO logic  
Relay logic HIGH is  $PV < SV$ , relay ON  
Relay logic LOW is  $PV > SV$ , relay ON
- Program the setpoint no. 2 value
- Program the hysteresis of setpoint no. 2 between 2 to 99 counts
- Program the relay logic of setpoint no. 2 between high or low logic.

**I.1 Totalizer Mode**



As user enters in the totalizer mode display shows the message as below.



Display indicates whether to reset the totalizer.value To reset, press the increment key. Last digit of volume display shows Y or N. Press enter key to complete the action.



If user want to reset the totalizer reading, press enter when display indicates the message as shown in the figure.



Display indicates whether to resume the totalizing function.



Display indicates whether to pause the totalizing function.



**Note :**

1. In program mode if function key **F** is pressed at any point, unit will branch to auto mode.
2. All values followed by Enter key will be stored, else the value will be discarded.
3. Steps to enter the password is shown on page no 17.
4. To change the present status user will be asked to enter the password which is 134.

**Operation**

Block Diagram

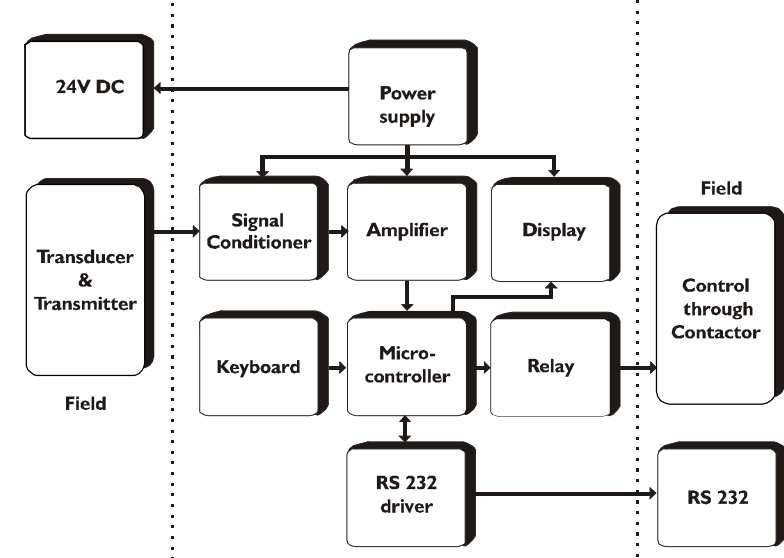

1. **Transducer :** This is externally connected to the instrument. This can be a 4 - 20 mA source or a 2 wire transmitter.
2. **Signal conditioner:** This circuit accepts the process signal from the sensor performs the necessary signal conditioning. and converts it into suitable signal level for ADC.
3. **ADC:** This is a 12 bit Successive Approximation type ADC inbuilt the microcontroller. It accepts the analog input signal, converts it into digital data and feeds it to the processor for further action.
4. **Microcontroller:** This is the heart of the unit and is interfaced to all other peripherals. The transducers, membrane keypad, display, memory and output relays function under the command of the microcontroller.

5. **Memory** : There are two memory elements provided in the circuit. One is the EPROM for monitor (main) program storage and the other is the NVRAM for storage of various user programmed parameters and process variables (even in events of prolonged power failure).
6. **Keypad** : Feather touch membrane keys are provided on the front panel for user programming. These keys have features like long life, negligible contact bounce, ease of operation.
7. **Display** : The front panel carries all the indications. These are controlled by the CPU. There are 2 nos. of LED displays. For flow rate there is a 4 digit 12.5 mm RED LED display and for Totalizer there is a digit 10 mm RED LED display.
8. **Output relays** : There are two relays outputs.
9. **RS 232** : Serial port is for communication with a PC. For mode details on this, pls refer the modbus protocol section.

**Installation procedure :**

The instrument should be mounted in a place where it is clearly visible and accessible.

1. Insert the instrument in a suitable cut out and fix it using the bracket pair provided on the sides.
2. Make the connections as shown in Rear View diagram.
3. All connections should be firm.
4. Connect the positive of the transmitter to '+' terminal of power supply. Connect the '-' terminal of transmitter to '+' terminal of input and negative of power supply to '-' terminal. i.e Connect the terminals in series with the transmitter.
5. Ensure proper earthing to the instrument.

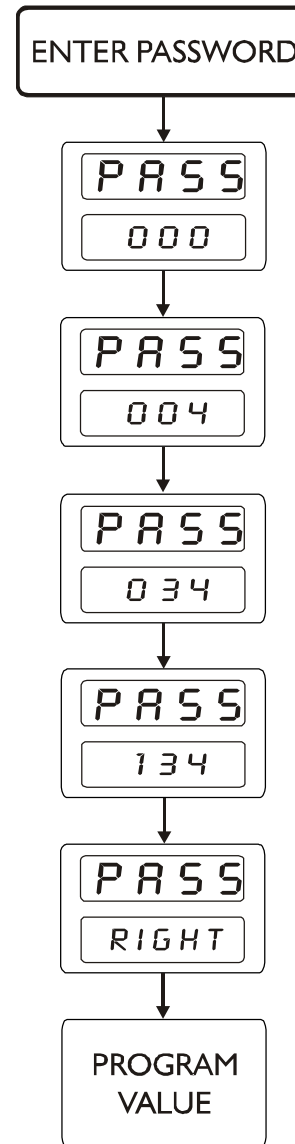

- ▲ By pressing increment key user can change the value by entering the right password
- ▲ As user asked to write the password unit displays message as shown
- ◀
- ▲ By using increment key user can change the value in ascending order from 0 to 9.
- ◀
- ▲ Blinking of the display indicates the current position of value. To change the digit position use the shift key
- ◀
- ▲ The default password to change any settings value is 134.
- ◀
- ▲ Display indicates user has entered a right password. Wrong message will be displayed if password is incorrect
- ▲ Now by entering the right password user can change the preassigned value.

By pressing the increment key unit displays

1.4) Input Calibration Mode

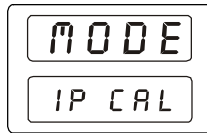

Here user can calibrate the instrument for the input range. By pressing the increment key unit displays

1.5) Output Calibration Mode

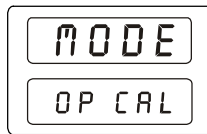

This is the output calibration mode. Here user can calibrate the retransmission output of 4 - 20 mA of the instrument.

Programming Flowchart

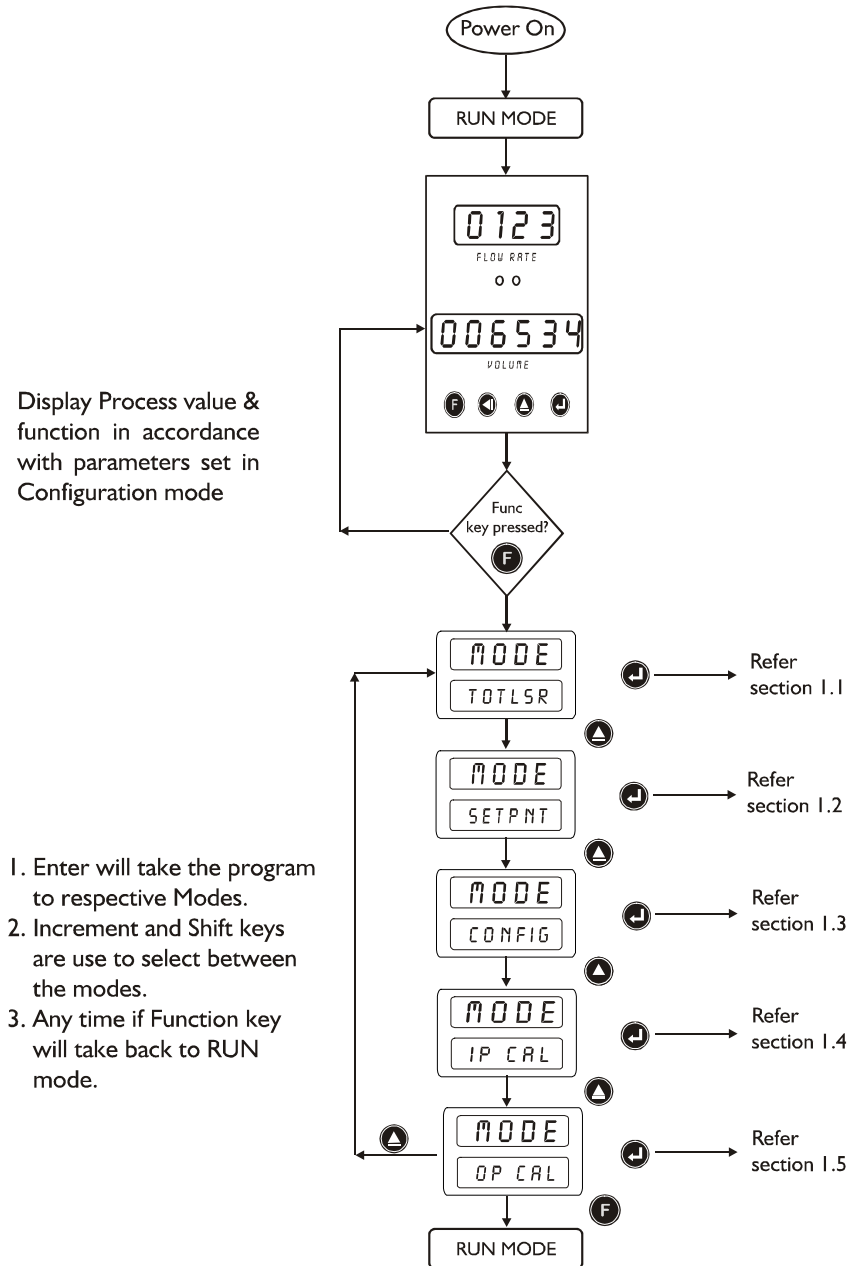

## Programming Procedure:

In this mode the user can program all the setpoints, control actions and other parameters. Pressing Function key in Run mode displays the following message.

### Section 1.1 : Totalizer mode

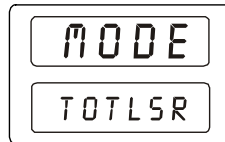

This is totalizer programming mode. In this mode, user can do the following.

- 1) Reset the totalizer.
- 2) Pause the totalizer.
- 3) Resume the totalizer if previously paused.

By pressing the increment key unit displays the following message

### Section 1.2 : Setpoint Mode

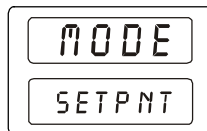

This is the setpoint setting mode. Here user can set the setpoint, hysteresis and relay logic of both the setpoints. By pressing the increment key unit displays

### Section 1.3 Configuration Mode

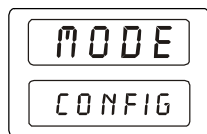

This is the configuration mode. User can set the following parameters in this mode.

#### 1.3.1) Decimal point setting.

User can select the decimal position of flow rate anywhere between units position to thousandth's position.

#### 1.3.2) Range setting.

Here user can set the lower limit followed by upper limit of the flow rate which corresponds to 4 to 20mA .

#### 1.3.3) Offset setting.

This is used to add or subtract a fixed value known as offset at the lower end of the range. This is used to eliminate transmitter error if any.

#### 1.3.4) Flow rate type setting

Here user can select the flow type between Linear and Square root type depending on the transmitter used.

#### 1.3.5) Time base

User can set the time base of flow rate which is used to compute the totalizer value between second, minute and hour .

#### 1.3.6) Setpoints On Flow or Totalizer

Here user can decide whether he wants to operate the setpoints on flow rate or on totalizer value. Both the setpoints can be individually configured on flow rate or totalizer.

#### 1.3.7) Communication settings.

Here user can set the Device address and baud rate parameters which are used for RS 485 or RS 232 communication. User can set the device address between 1 to 247 and baud rate between 4800 or 9600 kbps. Other parameters of communication are fixed and are as follows.

- a) Parity - None
- b) Data byte - 8 bit
- c) Stop bit - 1